

REVISIONS					
REV	ECO	DESCRIPTION	DATE	BY	APPR
A3	--	RELEASE NEW DWG FORMAT	18/SEP/13	DRP	
A4	--	UPDATE DRAWING	10/MAY/19	JOE	TOMMY

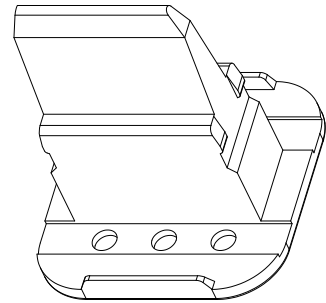
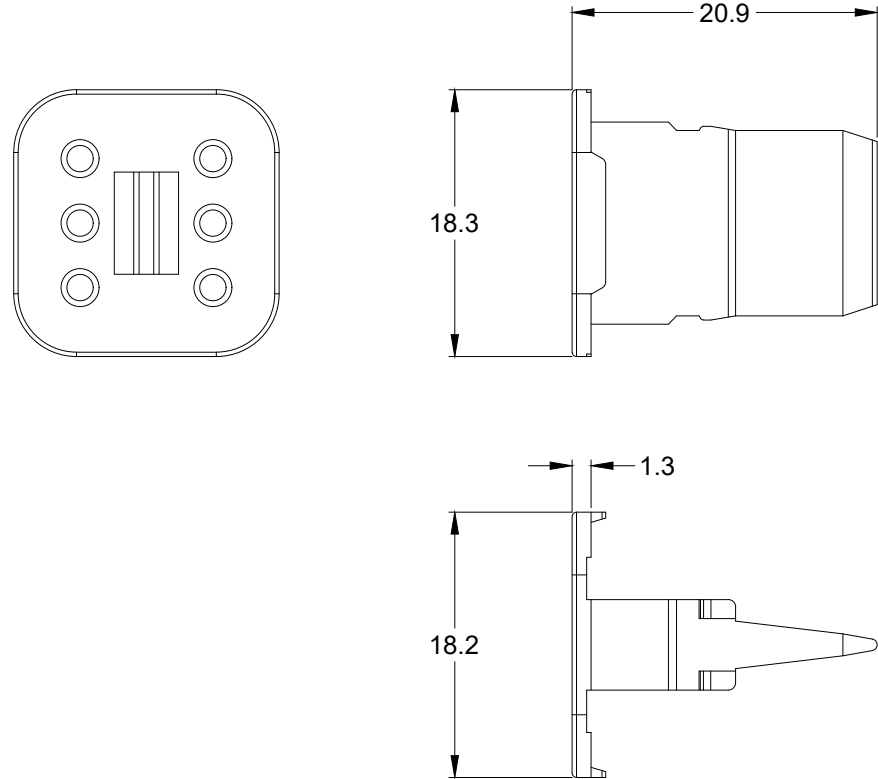

NOTES: UNLESS OTHERWISE SPECIFIED

1. MATERIAL: THERMOPLASTIC; COLOR: GREEN
2. RoHS COMPLIANT
3. CAVITIES: 6
4. KEYED: N/A
5. USE WITH CONNECTORS AT06-6S\*  
(\* = MODIFICATIONS AND COLORS)
6. ALL DIMENSIONS ARE FOR REFERENCE USE ONLY.

AW6S					
QUANTITY	PART NUMBER	DESCRIPTION			ITEM
<b>MATERIALS LIST</b>					
<b>UNLESS OTHERWISE SPECIFIED</b> 1) All dimensions are in metric(mm). 2) Tolerances are as follows: 1 PL DEC ±0.30      Fractions ±1/64 2 PL DEC ±0.15      Angles ±1° 3 PL DEC ±0.08 3) Note reference =		<b>SIGNATURES</b> <b>DATE</b> DRAWN:      JOE      10/MAY/19 CHECKED:      ORION      10/MAY/19 ENGINEER: APPROVAL:      TOMMY      10/MAY/19 CUSTOMER:		<h1 style="margin: 0;">Amphenol</h1> <p style="margin: 0;">Sine Systems - www.amphenol-sine.com                      44724 Morley Drive                      Clinton Township, MI 48036</p>	
MATERIAL SPECIFICATIONS:		THIS DRAWING IS SUPPLIED FOR INFORMATION ONLY. DESIGN FEATURES, SPECIFICATIONS AND PERFORMANCE DATA SHOWN HEREON ARE THE PROPERTY OF THE AMPHENOL CORPORATION. NO RIGHTS OF REPRODUCTION ARE IMPLIED. ALL DIMENSIONS ARE SUBJECT TO NORMAL MANUFACTURING VARIATIONS.		<b>S-WEDGELOCK, 6 POSITION, AT SERIES</b>	
PROCESS SPECIFICATIONS:		SIZE	TYPE	DWG NO:	REVISION
NEXT ASSY:		<b>A</b>	<b>C-</b>	<b>AW6S</b>	<b>A4</b>
		SCALE: <b>NONE</b>		SHEET <b>1</b> OF <b>1</b>	